

TP200 precision touch trigger probe

High precision TTP with stylus module changing

The TP200 was developed for tightly toleranced workpieces, and where access to features requires long or complex stylus arrangements.

High precision repeatability and 3D form measurement with long styli is achieved by employing a novel type of strain gauge structure to detect small displacements of the stylus tip.

In standard probes, where a mechanical switch generates the touch signal, the force required at the stylus tip to trigger the probe varies with the probing direction, producing small form measurement errors sometimes called 'lobing'. The TP200 overcomes this error by using electronic strain sensing to precisely detect the force produced by minute displacements of the stylus tip.

The TP200 system incorporates a probe body and separate stylus modules, providing rapid stylus changing and probe overtravel capability, and is compatible with Renishaw's probe heads and extension bars.



Key benefits

Superior measuring performance with stylus lengths up to 100 mm

TP200 is recommended for tightly toleranced workpieces and high density point taking applications. It is also suited to features requiring long or complex stylus arrangements.

Increase productivity

Fast, automatic stylus changing and stylus module life typically in excess of 10 million triggers, increase productivity, saving time and costs.

Rapid and easy exchange of styli with a one-off qualification

Allows optimisation of stylus arrangements, dealing with conflicting requirements such as feature access, surface finish and accuracy.

Innovations

Strain-gauge technology

TP200 sensor technology gives sub-micron triggering performance and eliminates the lobing characteristics encountered with standard 'kinematic touch probes'.

Solid state ASIC electronics

The solid state ASIC electronics within the probe ensure reliable operation over millions of trigger points.

Rapidly interchangeable stylus modules

Standard force (SF) and low force (LF) stylus modules are available. The latter designed for use with small ball styli or on delicate materials. In addition, an extended overtravel (EO) module, provides increased protection against CMM motion overrun. Module changing can be achieved using the SCR200 stylus change rack.

Specification

| | |
|---|---------------------------------|
| Mounting | M8 connector |
| Suitable interface | PI200 |
| Sense directions | 6-way, $\pm X$, $\pm Y$, Z |
| Modules available | SF, LF, EO |
| Unidirectional repeatability (maximum mean 2σ at stylus tip) | |
| Trigger level 1: | 0.4 μm (0.000016 in) |
| Trigger level 2: | 0.5 μm (0.00002 in) |
| Pretravel variation (XY plane) | |
| Trigger level 1: | 0.8 μm (0.000032 in) |
| Trigger level 2: | 0.9 μm (0.000036 in) |
| Weight (probe and module) | 22 g (0.8 oz) |
| Trigger force (XY plane) | |
| SF/EO: | 0.02 N |
| LF: | 0.02 N |
| Trigger force (Z plane) | |
| SF/EO: | 0.07 N |
| LF: | 0.07 N |
| Overtravel force (XY plane) | |
| SF/EO: | 0.2 N – 0.4 N |
| LF: | 0.1 N – 0.15 N |
| Overtravel force (Z plane) | |
| SF/EO: | 4.9 N @ 0.5 mm displacement |
| LF: | 1.6 N @ 0.5 mm displacement |
| Maximum extension on PH10 series | 300 mm (11.8 in) |
| Change rack system | SCR200 |
| Stylus range | M2 |

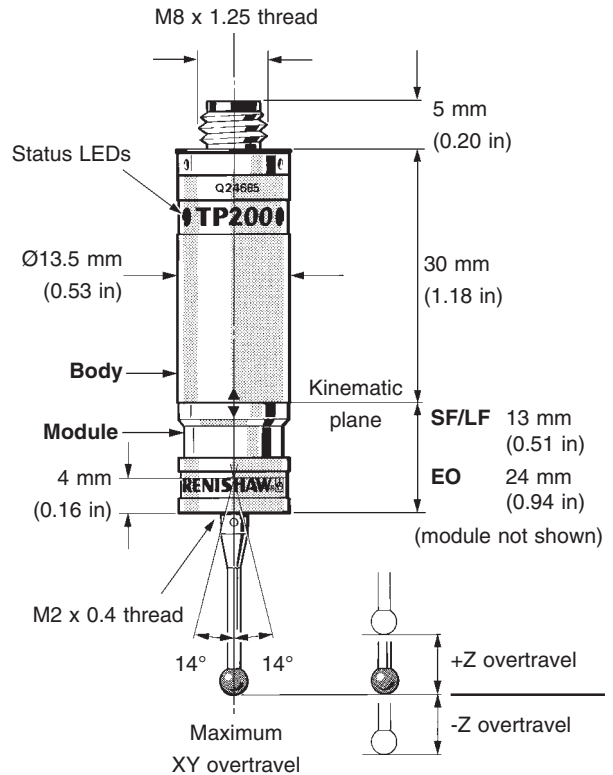

+Z overtravel

| | |
|--------------|-------------------|
| SF/LF | 4.5 mm (0.18 in) |
| EO | 12.5 mm (0.49 in) |

-Z overtravel (separation of the module from the body)

| | |
|-----------------|----------------|
| SF/LF/EO | 4 mm (0.16 in) |
|-----------------|----------------|

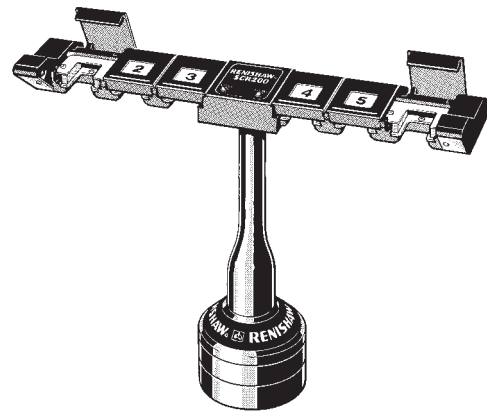

SCR200 change rack

Additional information

Renishaw has also developed the TP200B, offering high accuracy performance free of vibration false triggering.

For further details on this and other related products, please see www.renishaw.com/TP200.

For worldwide contact details, please visit our main website at www.renishaw.com/contact