

Touch-trigger probe systems



**TP1, TP2, TP6, TP6A, PH1,
PH5, PH6, PH6M**

© 1987 - 2003 Renishaw plc. All rights reserved.

Renishaw® is a registered trademark of Renishaw plc.

This document may not be copied or reproduced in whole or in part, or transferred to any other media or language, by any means, without the prior written permission of Renishaw.

The publication of material within this document does not imply freedom from the patent rights of Renishaw plc.

Disclaimer

Considerable effort has been made to ensure that the contents of this document are free from inaccuracies and omissions. However, Renishaw makes no warranties with respect to the contents of this document and specifically disclaims any implied warranties. Renishaw reserves the right to make changes to this document and to the product described herein without obligation to notify any person of such changes.

Care of equipment

Renishaw probes and associated systems are precision tools used for obtaining precise measurements and must therefore be treated with care.

Changes to equipment

Renishaw reserves the right to improve, change or modify its hardware or software without incurring any obligations to make changes to Renishaw equipment previously sold.

Warranty

Renishaw plc warrants its equipment for a limited period (as set out in our Standard Terms and Conditions of Sale) provided that it is installed exactly as defined in associated Renishaw documentation. Prior consent must be obtained from Renishaw if non-Renishaw equipment (e.g. interfaces and/or cabling) is to be used or substituted for Renishaw equipment. Failure to comply with this will invalidate the Renishaw warranty. Claims under warranty must be made from authorised Service Centres only, which may be advised by the supplier or distributor.

Patents

Features of the products shown in this guide, and features of similar products, are the subjects of the following patents and patent applications.

EP 0142373

EP 0293036

JP 2,098,080

US 4651405

Renishaw part no: H-1000-5021-06-B

Issued: 02 2003

H-1000-5021-06-B

Touch-trigger probe systems User's guide

TP1, TP2, TP6, TP6A, PH1, PH5, PH6, PH6M

RENISHAW 

Renishaw plc,
New Mills,
Wotton-under-Edge,
Gloucestershire,
GL12 8JR,
United Kingdom

T: +44 (0)1453 524524

F: 44 (0)1453 524901

E: uk@renishaw.com

www.renishaw.com

GB

WARNINGS

Pinch hazards exist between parts and between moving and static parts. Do not hold the probe head during movements, or during manual probe changes.

Beware of unexpected movement. The user should remain outside of the full working envelope of probe head/extension/probe combinations.

In all applications involving the use of machine tools or CMMs, eye protection is recommended.

For instructions regarding the safe cleaning of Renishaw products, refer to the **Maintenance** section of the relevant product documentation.

Remove power before performing any maintenance operations.

Refer to the machine supplier's operating instructions.

It is the machine supplier's responsibility to ensure that the user is made aware of any hazards involved in operation, including those mentioned in Renishaw product documentation, and to ensure that adequate guards and safety interlocks are provided.

Under certain circumstances the probe signal may falsely indicate a probe seated condition. Do not rely on probe signals to stop machine movement.

Contents

1	Introduction	5
2	Probe system overview	6
3	Probes product overview	6
3.1	Principles of operation	7
4	Probe description and operation	8
4.1	TP1(S) touch-trigger probe	8
4.2	TP2 - 5-way touch-trigger probe	9
4.3	TP6 touch-trigger probe	10
4.4	TP6A touch-trigger probe	11
5	Installation	12
5.1	Electrical installation	12
5.2	Fitting a stylus	13
6	Applications guide	14
6.1	Stylus selection	14
6.2	Trigger force	15
7	Manual probe heads product overview	20
8	Manual probe heads description and operation	22
8.1	PH1 manual probe head	22
8.2	PH5 manual probe head	27
8.3	PH5/1 manual probe head	30
8.4	PH6 manual probe head	34
8.5	PH6M manual probe head	38
9	Installing a manual probe head	39
9.1	Fitting an M8-threaded CMM touch-trigger probe to a manual probe head	39
9.2	Fitting an autojointed CMM touch-trigger probe to a manual probe head	41
9.3	Attaching a shank to a manual probe head (except PH6) ..	42
9.4	Connecting a manual probe head electrically to a CMM	44

10	Maintenance - Cleaning	45
11	Accessories	45
11.1	Styli	45
12	Fault-finding guide	46
12.1	Poor measurement performance	47
12.2	Unwanted triggers during CMM movement	48
12.3	No probe signal	48
12.4	Probe fails to re-arm after trigger	49
13	Technical product specifications	50

1 Introduction

Co-ordinate Measuring Machines (CMMs) have evolved from their origins in simple layout machines and manually operated systems, to highly accurate, automated inspection centres.

A major factor in this evolution has been the touch-trigger probe and other forms of inspection probe, together with subsequent Renishaw innovations such as the motorised probe head and automatic probe exchange system for unmanned, flexible inspection.

It all began with Rolls-Royce engines for the Anglo-French Concorde when a unique solution was required for accurate pipe measurement. The result was the first touch-trigger probe: a 3D sensor capable of rapid, accurate inspection with low trigger forces. From this unique starting point, Renishaw has established a range of precision probes and accessories for CMMs unequalled around the world.

Renishaw's success has been made possible by the close working relationship the company enjoys with CMM manufacturers and users. The market is constantly striving to extend the frontiers of inspection technology. By close liaison throughout the design, development and evaluation processes, Renishaw keeps in step with the market's needs ... and, in many cases, one step ahead.

From the Group's centre of operations in Wotton-under-Edge, Renishaw's products are exported to the world's leading industrialised nations; a fact that has been rewarded by nine Queen's Awards.

2 Probe system overview

In the context of this User's guide a probe system comprises a stylus mounted onto a touch trigger probe that in turn is connected to a CMM using a manual probe head.

The intention of this guide is to cover the most common combinations of the manual probe heads and touch-trigger probes in an attempt to assist the user in making a product choice that is best for any particular application.

The guide covers the features of each of the standard kinematic touch trigger probes (see sections 3 to 6) and complementary manual probe heads (see sections 7 to 9).

3 Probes product overview

Renishaw's CMM touch-trigger probes detailed in this User's Guide are designed to suit any CMM, but their individual characteristics are outlined below:

- | | |
|-------------|---|
| TP1(S) | A robust shank-mounted probe offering generous overtravel – ideally suited to manual CMMs. |
| TP2 - 5-way | A compact probe allowing component penetration – ideally suited to CNC/DCC machines. |
| TP6 | Complementing the TP2 series, but carrying longer and heavier styli, this probe is suited to general-purpose applications. |
| TP6A | This probe has all the functions of the TP6 probe and in addition the patented Renishaw autojoint that permits fast probe exchange without the need to requalify. |

Renishaw also manufacture other touch-trigger probes which are not detailed in the User's Guide.

For details of these and other Renishaw products, visit the Renishaw website at www.renishaw.com.

3.1 Principles of operation

The principle component of Renishaw touch-trigger probes is the *kinematic location* as shown in Figure 1 below – a mechanical device that has the ability to return the stylus ball to the same repeatable position following any deflection.

The kinematic location consists of a pivotal plate [1] that is spring-loaded against three bearing points [2] by a helical compression spring [3]. These bearing points are formed by a combination of rollers and ball bearings.

Bearing points act as electrical contacts such that when the pivotal plate is deflected, the electrical circuit changes its characteristics and causes the probe interface to send a trigger to the CMM controller.

Following this trigger event, the stylus ball must be removed from contact with the surface to enable the probe to return the stylus ball to its repeatable position.

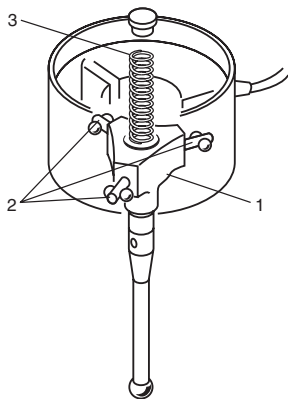

Figure 1 – Kinematic location

4 Probe description and operation

4.1 TP1(S) touch-trigger probe

The TP1(S) touch-trigger probe illustrated in Figure 2 is a robust shank-mounted probe with a generous overtravel which is especially suited to manual CMMs. It is of a maintenance-free, sealed construction to provide a long working life.

The TP1(S) incorporates an M3 stylus mount which ensures compatibility with Renishaw's extensive M3 and M2 stylus and accessory range using the appropriate stylus adaptor where necessary.

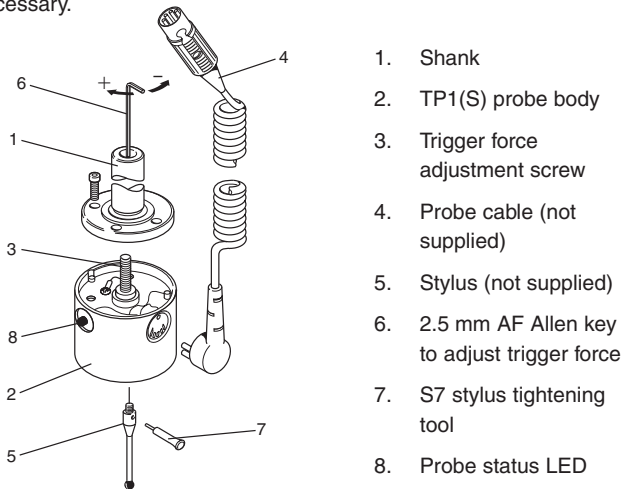

Figure 2 – TP1(S) touch-trigger probe

4.2 TP2 - 5-way touch-trigger probe

The TP2 - 5-way touch-trigger probe shown in Figure 3 is a compact (13mm diameter) general-purpose probe suitable for use on all types of CMM. It has an M8 mounting thread that ensures compatibility with Renishaw's comprehensive range of probe heads and extension bars.

The TP2 is of a maintenance-free construction to provide a long working life.

It incorporates an M2 stylus mount giving access to Renishaw's extensive M2 stylus range and accessories.

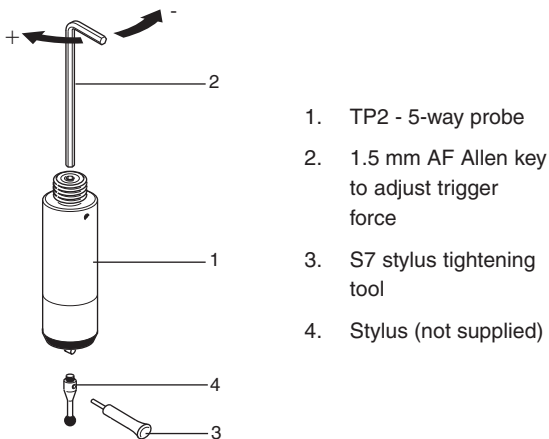

Figure 3 – TP2 - 5-way touch-trigger probe

4.3 TP6 touch-trigger probe

The TP6 touch-trigger probe illustrated in Figure 4 combines the accuracy, flexibility and M8 mounting thread of the TP2 - 5-way probe with the rugged construction and generous overtravel of the TP1(S).

The larger diameter of the TP6 (25 mm) allows the probe to carry longer and heavier styli configurations than the TP2 - 5-way, allowing it to be used successfully on both universal DCC and manual CMMs.

It incorporates an M3 stylus mount which allows compatibility with Renishaw's extensive M3 and M2 stylus and accessory range using the appropriate stylus adaptor where necessary.

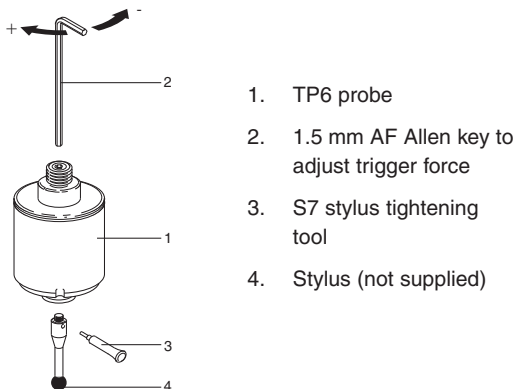

Figure 4 – TP6 touch-trigger probe

4.4 TP6A touch-trigger probe

The TP6A touch-trigger probe has all the features of the TP6 with the added benefit of the Renishaw autojoint. This is a highly repeatable kinematic joint which allows rapid probe exchange without the need to requalify the probe tip. It can be operated either manually, using an S10 autojoint key, or automatically, using the autochange rack system.

This probe can be used successfully on both universal DCC and manual CMMs. It incorporates an M3 stylus mount which offers compatibility with all Renishaw's extensive M3 and M2 stylus and accessory range.

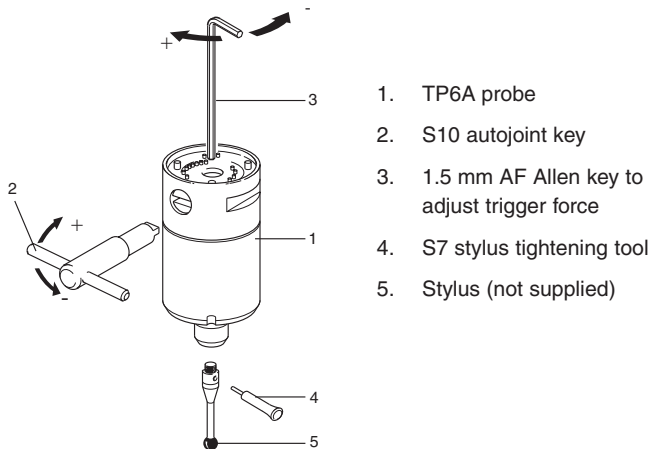

Figure 5 – TP6A touch-trigger probe

5 Installation

5.1 Electrical installation

5.1.1 TP1(S)

The 5-pin DIN socket on the TP1(S) probe provides the connections shown in Figure 6 and Table 1 below to the probe interface.

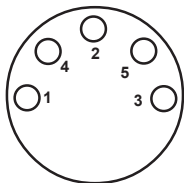

Figure 6 – 5-pin DIN socket

Table 1 - Pin functions	
Pin	Function
1	LED cathode
2	Screen
3	LED anode
4	Probe circuit
5	Probe circuit

5.1.2 TP2 and TP6

Connections to the probe interface are made through the M8 mounting joint.

5.1.3 TP6A

Connections to the probe interface are made through the autojoint.

5.2 Fitting a stylus

To fit a stylus to a Renishaw touch-trigger probe, insert the correct threaded stylus or stylus adaptor into the stylus mount and tighten the stylus securely using the S7 stylus tool provided. See Figure 7.

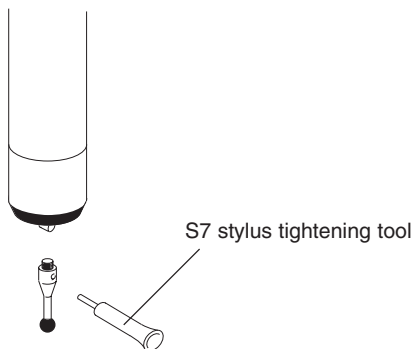

Figure 7 – Fitting a stylus



Tightening the stylus by any means other than the stylus tool provided (e.g. spanners, drill bits, etc.) may cause internal damage to the probe mechanism.

NOTE: All stylus joints should be clean and free from dirt or debris.

6 Applications guide

6.1 Stylus selection

In the majority of probing applications, to maximise accuracy we recommend that you:

- **Keep styli short and stiff**

The more the stylus bends or deflects, the lower the accuracy. Probing with the minimum stylus length for your application is recommended and where possible the use of one piece styli is suggested. Probing with excessive styli/extension combinations should therefore be avoided.

- **Keep the stylus ball as large as possible**

This will ensure maximum ball/stem clearance whilst providing a greater yet rigid Effective Working Length (EWL). Using larger ruby balls also reduces the effect of surface finish of the component being inspected.

EWL is the penetration that can be achieved by any ruby ball before its stem fouls against the feature. Generally, the larger the ball diameter, the greater the EWL (see Figure 8).

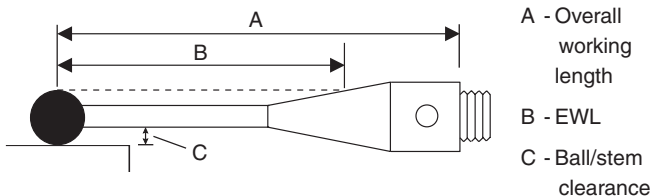

Figure 8 – Effective working length

EWL can also be affected by assembly tolerances. For this reason, Renishaw styli are assembled to exacting standards in controlled conditions.

6.2 Trigger force

Trigger force is the amount of pressure applied by the helical compression spring onto the pivotal plate and bearing points to hold the stylus mount in place (see section 3.1).

The trigger force is preset by Renishaw but can be altered for any of the following reasons:

- to permit the use of longer styli on the probe
- to permit the use of heavier styli on the probe
- if the preset trigger force has decreased due to probe use
- if the acceleration of the CMM is causing illegal triggers

NOTE: Changing the probe trigger force will affect the probe's measurement performance. It is important to requalify the probe configuration and check the measurement performance of the probe system after any adjustment has been made to the trigger force.

All Renishaw's touch-trigger probes have an optimum trigger force setting for general purpose applications as detailed in Table 2.

Table 2 - Trigger force			
CMM probes	Stylus length (typical)	Optimum trigger force (preset by Renishaw)	Trigger force range
TP1(S)	31 mm (PS1-1R)	0.15 N	0.1 - 0.5 N
TP2 - 5 way	10 mm (PS12R)	0.07 - 0.08 N	0.07 - 0.15 N
TP6/TP6A	21 mm (PS1-12R)	0.11 - 0.13 N	0.11 - 0.3 N

6.2.1 Checking trigger force with the Renishaw gram gauge

1. Ensure that the probe is held firmly in position (preferably on a CMM) and connected to an interface to detect a probe trigger.
2. Establish the direction of trigger which gives the minimum resistance. The most practical way of doing this is to gently deflect the stylus with a finger, trying different directions (see Figure 9). There are three lobes which produce three maximum and three minimum force directions. These can easily be found with a minimum of practice.

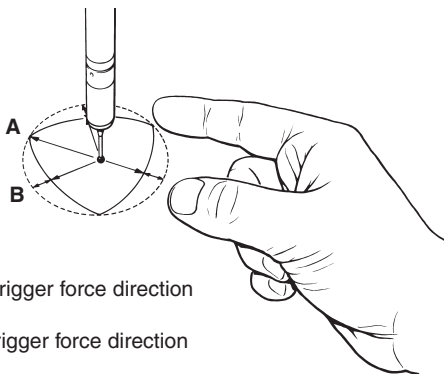

A = High trigger force direction

B = Low trigger force direction

Figure 9 – Establishing direction of minimum resistance

3. Set the gram gauge maximum force indicator to the zero point and place the gram gauge flat on the CMM table. Move the stylus tip to the same height above the surface as the gram gauge lever.
4. Slide the gram gauge slowly sideways so that the flat point on the end of the lever touches the probe stylus ball (ensuring that the probe is deflected in the low force direction). Very slowly continue to move the gram gauge until the probe triggers, at which point stop immediately, back off the gauge and read the maximum force indicator (see Figure 10).
5. Repeat this procedure three or four times to ensure consistent results.

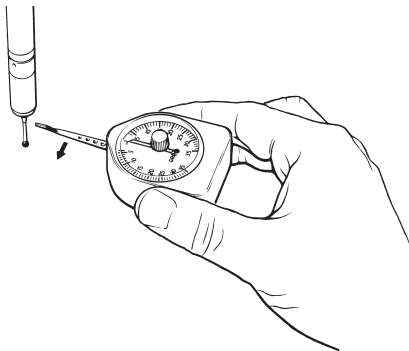

Figure 10 – Measuring trigger force

NOTE: To convert gf to Newtons the following formula is required:

$$\text{Newtons} = \text{gf} / 100$$

6.2.2 Trigger force adjustment – TP1(S)

The trigger force of a TP1(S) probe is preset by Renishaw at an optimal performance setting, but can be altered if necessary as follows:

1. Remove the probe from the quill of your CMM.
2. Insert a 2.5 mm AF Allen key (supplied with every probe) into the centre of the shank until you locate a grub screw.
3. Adjust this grub screw to alter the trigger force of the probe:
 - Clockwise increases the trigger force
 - Anticlockwise decreases the trigger force

6.2.3 Trigger force adjustment – TP2 and TP6

The trigger force of TP2 and TP6 probes is preset by Renishaw at an optimal performance setting, but can be altered if necessary as follows:

1. Remove the probe from the probe head on the quill of your CMM.
2. Insert a 1.5 mm AF Allen key (supplied with every probe) into the hole in the centre of the M8 thread until you locate a grub screw.
3. Adjust this grub screw to alter the trigger force of the probe:
 - Clockwise increases the trigger force
 - Anticlockwise decreases the trigger force

6.2.4 Trigger force adjustment – TP6A

The trigger force of a TP6A probe is preset by Renishaw at an optimal performance setting, but can be altered if necessary as follows:

1. Remove the probe from the probe head on the quill of your CMM.
2. Ensure that the cam of the autojoint is in the unlocked position.
3. Insert a 1.5 mm AF Allen key (supplied with every probe) through the cam towards the centre of the TP6A until you locate a grub screw.
4. Adjust this grub screw to alter the trigger force of the probe:
 - Clockwise increases the trigger force
 - Anticlockwise decreases the trigger force

7 Manual probe heads product overview

Renishaw manual probe heads detailed in this User's guide are designed to suit any CMM and this specifically covers:

- PH1
- PH5
- PH5/1
- PH6
- PH6M

Each is designed for a specific application and purpose (see Table 3 – Probe head/touch trigger probe compatibility). Figure 11 explains the product interconnections and both include the MH8 and MIH for completeness.

Probe head	No. of probes carried	Orientation			Probe joint
		A-axis	B-axis	Repeatable	
PH1	1	✓	✓	✗	M8 bush
PH5	<5 (1*)	✗	✗	✗	M8 bush
PH5/1	<5 (1*)	✗	✓	✗	M8 bush
PH6	1	✗	✗	✗	M8 bush
PH6M	1	✗	✗	✓	Autojoint
MIH	1	✓	✓	✓	Autojoint
MH8	1	✓	✓	✓	M8 bush

* This probe head can only connect one electronic probe (e.g. TP200).

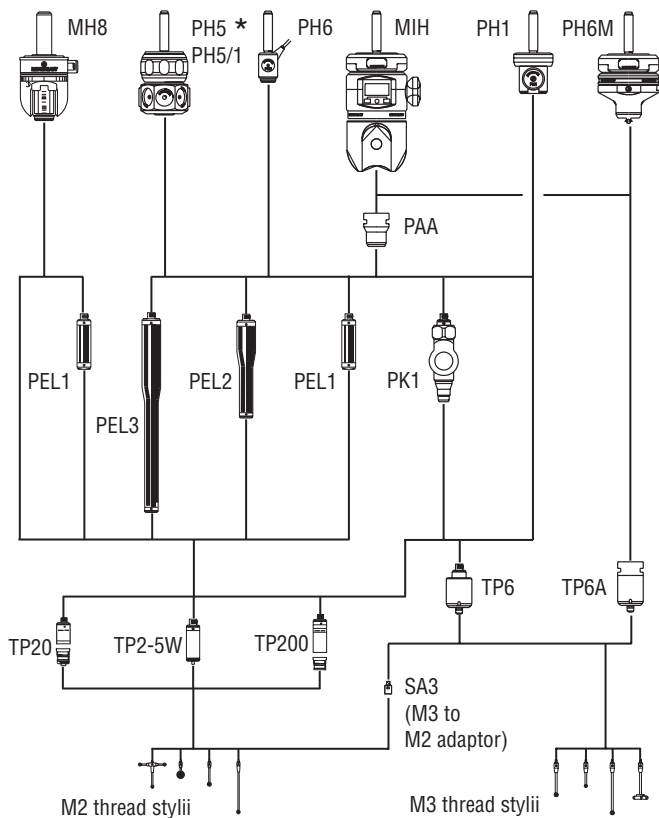

Figure 11 – Renishaw manual probe heads

* This probe head can only connect one electronic probe (eg. TP200).

8 Manual probe heads description and operation

Renishaw manual probe heads provide the mechanical and electrical connections required when using the majority of Renishaw touch-trigger probes on a Co-ordinate Measuring Machine (CMM).

Installed within the quill of the CMM via the shank supplied, a manual probe head permits a CMM touch-trigger probe to be held rigidly in position. It also allows a touch-trigger probe to be connected to a Renishaw probe extension bar and probe knuckle joint for improved probe orientation and component penetration (where indicated).

8.1 PH1 manual probe head

The PH1, shown in Figure 12, is a general purpose, swivel-type probe head. Its compact design makes it ideally suited to a CMM where manual orientation of a Renishaw M8 touch-trigger probe is required.

The PH1 provides two axes of movement. The A-axis allows probe orientation in the vertical plane; the B-axis allows rotational probe orientation. Axis rotation is in relation to the shank mount.

The PH1 manual probe head incorporates the following primary components and is supplied with the following tools:

- PH1 probe head [1]
- Probe cable (to probe interface) [2]
- Shank [3]
- 2.5 mm AF Allen key [4] (for tightening the shank socket screws)
- 2.0 mm AF Allen key [5] (for adjusting the B-axis locking force)

- Probe status LED [6]
- 3.0 mm AF Allen key [7] (for adjusting the A-axis orientation)

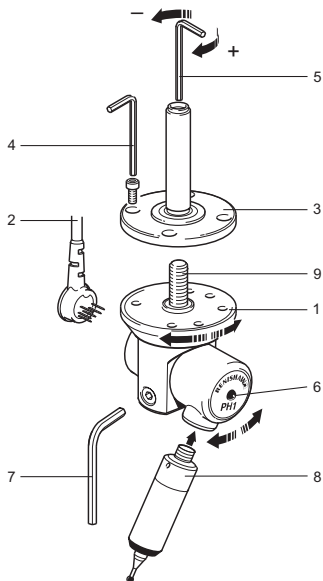

- | | |
|-------------------------------|---|
| 1. PH1 probe head | 6. Probe status LED |
| 2. Probe cable (not supplied) | 7. 3.0 mm AF Allen key |
| 3. Shank | 8. TP2 5-way touch-trigger probe (not supplied) |
| 4. 2.5 mm AF Allen key | 9. B-axis force adjustment screw |
| 5. 2.0 mm AF Allen key | |

Figure 12 – PH1 probe head

The A-axis may be swivelled through $\pm 115^\circ$ and locked in position using the 3.0mm AF Allen key [7] supplied. For instructions on how to move and lock the A-axis, see section 8.1.3, “Moving and locking the A-axis”.

The B-axis is indexable, in 15° steps, through 360° . For instructions on how to move and lock the B-axis, see section 8.1.4, “Moving and locking the B-axis”.

Connection of the PH1 to the CMM is via the probe cable [2] and an appropriate probe interface (not supplied).

The status of the probe is indicated by the probe status LED [6]. This is normally lit when the probe is ready for use and extinguishes as the probe triggers.

8.1.1 Technical data – PH1

Number of sockets:	One
Style of probe joint:	M8 bush
Probe status indication:	One LED located on the A-axis swivel
Cable connection:	Renishaw standard 5-pin DIN 180° socket
Overtravel break load:	Adjustable from 0.02 kgf (0.44 lbf) to locked solid
A-axis indexing:	$\pm 115^\circ$
B-axis indexing:	15° steps through 360°
Weight (excluding shank):	125 g (0.28 lb)

8.1.2 Installing and connecting the PH1

For instructions on how to install and connect the PH1, see section 9, “Installing a manual probe head”.

8.1.3 Moving and locking the A-axis

The A-axis may be swivelled through $\pm 115^\circ$ and locked in any position. Do this as described below (see Figure 13):

1. Insert the 3.0 mm AF Allen key [2] (supplied) into the Allen cap-head screw [1] located within the B-axis body.
2. Rotate the Allen key [2] in the counter-clockwise direction to release the holding pressure on the A-axis [3].
3. Swivel the A-axis [3] into the required position.
4. Hold the A-axis [3] in this position, and reassert the holding pressure on the A-axis by rotating the Allen key [2] in the clockwise direction.

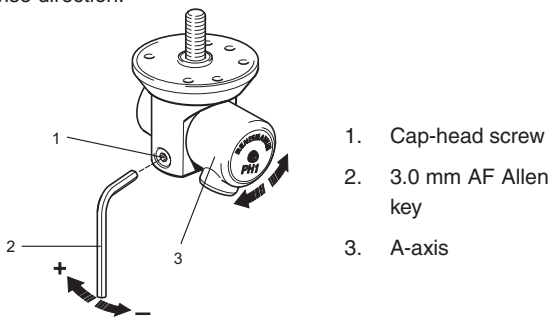

Figure 13 – Moving and locking the A-axis (PH1)

8.1.4 Moving and locking the B-axis

The B-axis locking force of the PH1 can be adjusted so that no B-axis rotation is possible. If the PH1 will not index by hand, the locking force must be decreased.

To decrease the locking force, see section 8.1.4.2, “Locking the B-axis”.

8.1.4.1 Moving the B-axis

The B-axis of the PH1 can be indexed in 15° increments throughout the 360° axis of rotation. Do this as described below:

1. Hold the A-axis of the PH1.
2. Rotate the B-axis of the probe to the required step.
3. Release the A-axis.

8.1.4.2 Locking the B-axis

Adjust the holding force of the B-axis as described below (see Figure 14):

1. With the PH1 removed from the quill of the CMM, insert the 2.5 mm AF Allen key [1] into the centre of the shank [2] until it locates the head of the B-axis force adjustment screw [3].
2. Adjust the B-axis force adjustment screw [3] as follows:
 - Rotate clockwise to **increase** the holding force.
 - Rotate counter-clockwise to **decrease** the holding force.

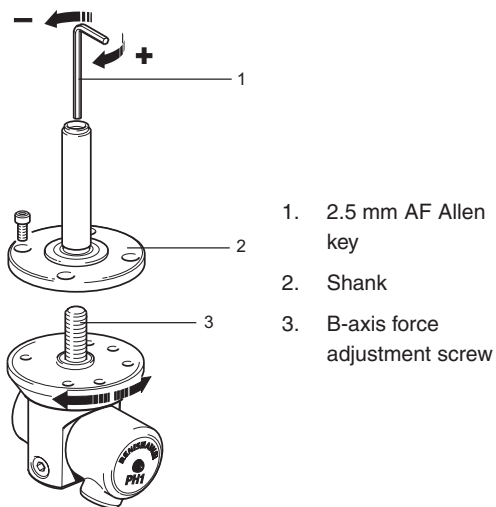

Figure 14 – Locking the B-axis (PH1)

8.2 PH5 manual probe head

The PH5, shown in Figure 15, is a compact probe head that is capable of carrying up to five TP2 or TP6 touch-trigger probes simultaneously, or one TP200 strain gauge probe.

The PH5 incorporates the following primary components and is supplied with the following tools:

- PH5 probe head [1]
- 2.5 mm AF Allen key [2] (for tightening shank socket screws)
- Shank [3]
- Two probe status LEDs [5]
- Five socket covers [6]
- Five insulating washers [7]

The status of the probe is indicated by the probe status LEDs [5]. These are normally lit when the probe is ready for use and extinguish as the probe triggers.

8.2.1 Technical data – PH5

Number of probe sockets:	Five
Style of probe joint:	M8 bush
Probe status indication:	Two LEDs
Electrical connection:	Standard Renishaw 5-pin DIN socket
Weight (excluding shank):	184 g (0.41 lb)

8.2.2 Installing and connecting the PH5

For instructions on how to install and connect the PH5, see section 9, “Installing a manual probe head”.

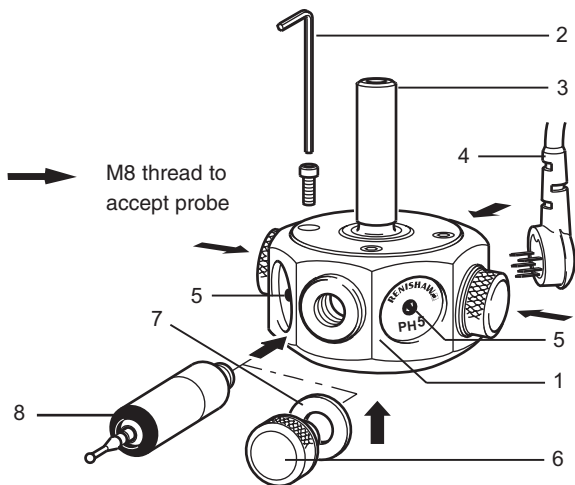

- | | |
|-------------------------------|---|
| 1. PH5 probe head | 5. Probe status LED (2 off) |
| 2. 2.5 mm AF Allen key | 6. Socket cover (5 off) |
| 3. Shank | 7. Insulating washer (5 off) |
| 4. Probe cable (not supplied) | 8. TP2 5-way touch-trigger probe (not supplied) |

Figure 15 – PH5 manual probe head

NOTE: The PH5 probe head contains five M8 probe sockets. Each socket that does not contain a probe must be fitted with a socket cover [6] and insulating washer [7].

8.3 PH5/1 manual probe head

The PH5/1 probe head, shown in Figure 16, is similar to the PH5 model. It is a compact unit that is capable of carrying up to five TP2 or TP6 touch-trigger probes simultaneously, or one TP200 strain gauge probe.

It offers the additional features of positive indexing in the B-axis and limited overtravel protection.

The PH5/1 incorporates the following primary components and is supplied with the following tools:

- PH5/1 probe head [1]
- Overtravel/B-axis orientation unit [2]
- 2.5 mm AF Allen key [3] (for tightening shank socket screws)
- Shank [4] LEDs [6]
- Five socket covers [7]
- Five insulating washers [8]

The status of the probe is indicated by the probe status LEDs [6]. These are normally lit when the probe is ready for use and extinguish as the probe triggers.

NOTE: The PH5/1 probe head contains five M8 probe sockets. Each socket that does not contain a probe must be fitted with a socket cover [7] and insulating washer [8].

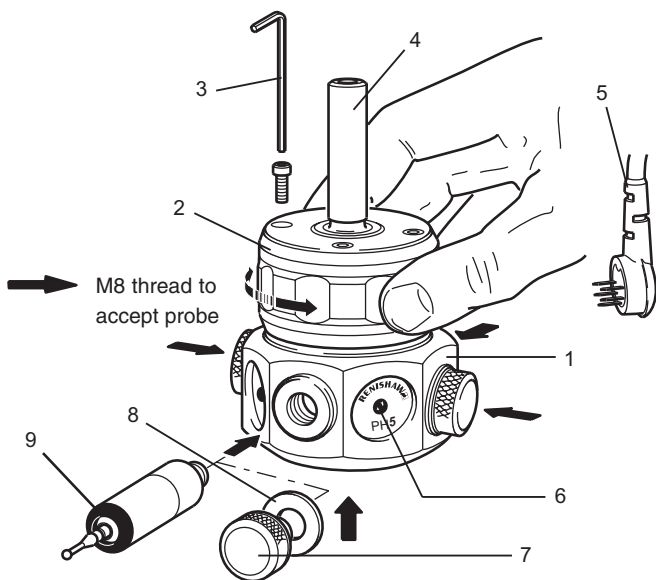

- | | |
|---------------------------------------|---|
| 1. PH5/1 probe head | 6. Probe status LED (2 off) |
| 2. Overtravel/B-axis orientation unit | 7. Socket cover (5 off) |
| 3. 2.5 mm AF Allen key | 8. Insulating washer (5 off) |
| 4. Shank | 9. TP2 5-way touch-trigger probe (not supplied) |
| 5. Probe cable (not supplied) | |

Figure 16 – PH5/1 manual probe head

8.3.1 Technical data – PH5/1

Number of sockets:	Five
Style of probe joint:	M8 bush
Probe status indication:	Two LEDs
Cable connection:	Renishaw standard 5-pin DIN socket
Overtravel break load: locked solid	Adjustable from 0.02 kgf (0.44 lbf) to locked solid
A-axis indexing:	Not applicable
B-axis indexing:	15° steps through 360°
Weight (excluding shank):	290 g (0.64 lb)

8.3.2 Installing and connecting the PH5/1

For instructions on how to install and connect the PH5/1, see section 9, “Installing a manual probe head”.

8.3.3 Moving and locking the B-axis

The B-axis locking force of the PH5/1 can be adjusted so that no B-axis rotation is possible. If the PH5/1 will not index by hand, then the locking force must be decreased.

To decrease the locking force, see section 8.3.3.2, “Locking the B-axis”.

8.3.3.1 Moving the B-axis

The B-axis of the PH5/1 can be indexed in 15° increments throughout the 360° axis of rotation.

NOTE: If the main body of the PH5/1 remains locked, see section 8.3.3.2, “Locking the B-axis”.

1. Hold the overtravel/B-axis orientation unit [2].
2. Rotate the probe head [1] to the required step.
3. Release the overtravel/B-axis orientation unit [2].

8.3.3.2 Locking the B-axis

Adjust the locking force of the B-axis as described below (see Figure 17):

1. Hold the knurled section of the overtravel/B-axis orientation unit [2].
2. Rotate the overtravel/B-axis orientation unit [2] to alter the locking force as follows:
 - Rotate clockwise to **increase** the holding force.
 - Rotate counter-clockwise to **decrease** the holding force.
3. Release the overtravel/B-axis orientation unit [2].

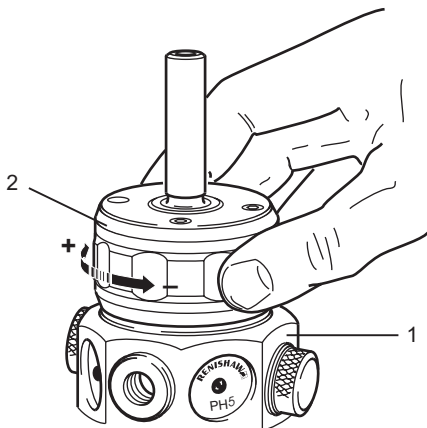

1. Probe head
2. Overtravel/B-axis orientation unit

Figure 17 – Moving and locking the B-axis (PH5/1)

8.4 PH6 manual probe head

The PH6, shown in Figure 18, is a compact, vertically mounted probe head that is ideally suited to a manual CMM where a single probe is required. It can be used with TP2, TP6, and TP20 touch-trigger probes.

The PH6 incorporates the following primary components:

- PH6 probe head/shank assembly with integral cable [1]
- Probe status LED [2]

The status of the probe is indicated by the probe status LED [2] that is located within the body of the probe head. During normal operation, the LED indicates the probe status as follows:

- **LED illuminated:** Probe is seated and is ready for use.
- **LED extinguished:** Probe has triggered / no probe is fitted.

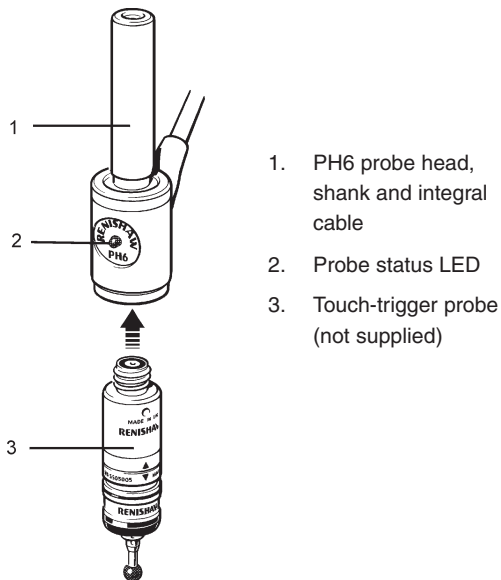

Figure 18 – PH6 manual probe head

8.4.1 Technical data – PH6

Number of sockets:	One
Style of probe joint:	M8 bush
Probe status indication:	One LED
Cable connection:	Dedicated integral cable
Weight (excluding shank):	48 g (0.11 lb)

8.4.2 Installing and connecting the PH6

For instructions on how to install and connect the PH6, see section 9, “Installing a manual probe head”.

The PH6 is fitted with an integral cable, connector, and shank. These cannot be changed.

8.4.3 PH6M manual probe head

The PH6M, shown in Figure 19, is a fixed probe head that incorporates the Renishaw autojoint [6]. It has the ability to convey complex probe signals via its 15-way micro ‘D’ connector, thus permitting the use of the Renishaw TP7 high accuracy touch-trigger probe and OPT6M optical touch-trigger probe.

The PH6M incorporates the following primary components and is supplied with the following tools:

- PH6M probe head [1]
- 2.5 mm AF Allen key [2] (for tightening shank socket screws)
- Shank [3]
- Probe status LED [5]
- Autojoint adaptor [6]
- S10 joint key [7]

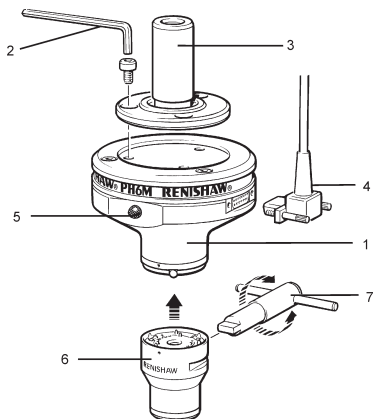

- | | |
|--|-------------------------------------|
| 1. PH6M probe head | 5. Probe status LED |
| 2. 2.5 mm AF Allen key | 6. Autojoint adaptor (not supplied) |
| 3. Shank | 7. S10 joint key |
| 4. Multiwired probe cable (not supplied) | |

Figure 19 – PH6M manual probe head

The probe head can be used with all Renishaw standard CMM touch-trigger probes and accessories. It can also be used with the PAA adaptor and M8 extension bars.

8.5 PH6M manual probe head

Locking and unlocking the autojoint is performed either manually using the S10 joint key [7] supplied, or automatically using the Renishaw autochange system. This allows probes to be changed without the need to requalify.

The status of the probe is indicated by the probe status LED [5]. This is normally lit when the probe is ready for use and extinguishes as the probe triggers.

8.5.1 Technical data – PH6M

Number of sockets:	One
Style of probe joint:	Multiwired autojoint
Probe status indication:	One LED
Cable connection:	15-way micro 'D' connector
Autojoint repeatability (2σ):	1 μm (0.00004 in.) using a TP6A touch-trigger probe and 21 mm stylus
Weight:	160 g (0.36 lb)

8.5.2 Installing and connecting the PH6M

For instructions on how to install and connect the PH6M, see section 9, “Installing a manual probe head”.

The PH6M is fitted with an integral 15-pin micro ‘D’ socket. If required, this socket can be adapted by using a suitable cable to which a 5-pin DIN socket has been fitted.

9 Installing a manual probe head

9.1 Fitting an M8-threaded CMM touch-trigger probe to a manual probe head

Fit an M8-threaded non-autojointed CMM touch-trigger probe to a manual probe head as described below (see Figure 20):

NOTE: The PH5 and PH5/1 probe heads contain five M8 probe sockets. Each socket that does not contain a probe must be fitted with a socket cover and insulating washer.

1. By hand, screw the threaded end of the touch-trigger probe into the M8 bush of the manual probe head and hand-tighten to secure.
2. Fit the S1 ‘C’ spanner (supplied) to the touch-trigger probe as shown in Figure 20.
3. Use the spanner to tighten the touch-trigger probe into the M8 bush.



The S1 'C' spanner is designed to break before any damage can occur to either the probe or the probe head due to over-tightening the probe.

Do not use any other tool to tighten the probe in the probe head as this could result in damage to both the probe and the probe head.

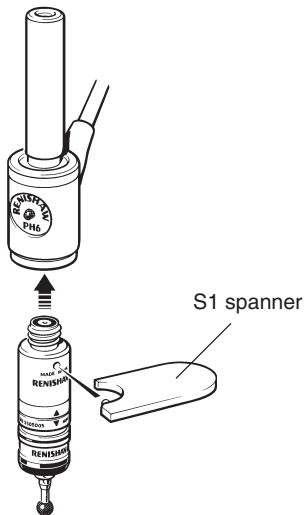

Figure 20 – Fitting a touch-trigger probe to a manual probe head (PH6 shown)

9.2 Fitting an autojointed CMM touch-trigger probe to a manual probe head

The repeatability of the Renishaw autojoint ensures that a probe need only be qualified once. The qualification data can then be recalled whenever the probe is re-attached.

Fit an autojointed CMM touch-trigger probe or PAA Series adaptor to a manual probe head as described below (see Figure 21):

1. Check that the locking cam on the autojointed probe is in the unlocked position (the slot is horizontal).
2. Offer up the autojointed probe to the PH6M, ensuring that the alignment marks on both the probe and the probe head are correctly aligned.

NOTE: If the TP6A touch-trigger probe is to be used in conjunction with the Renishaw autochange system, the TP6A should be locked to the probe head by rotating the cam fully clockwise and then reversing it by 5°.

3. Insert the S10 joint key into the cam of the autojointed probe and rotate clockwise (120°) to lock the probe to the probe head.

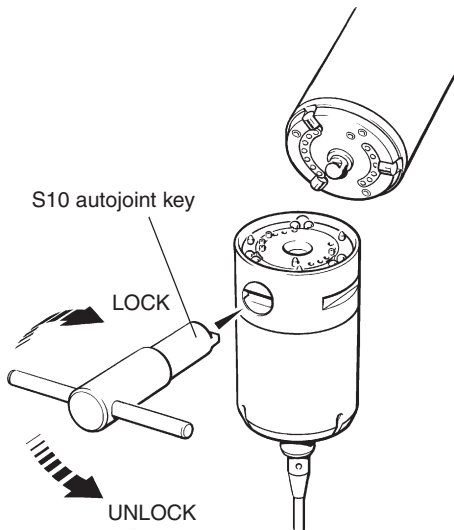

Figure 21 – Fitting an autojointed CMM touch-trigger probe to a manual probe head

9.3 Attaching a shank to a manual probe head (except PH6)

Renishaw products may incorporate either three or four tapped holes to facilitate fitting a shank. Renishaw shanks are supplied with five holes to allow either three-hole or four-hole products to be fitted to them.

Attach a Renishaw shank to a Renishaw manual probe head as described below (see Figure 22):

1. Locate the shank on to the top of the probe head.
2. Align the holes within the shank with those within the probe head.
3. Insert an M3 x 6 mm Allen cap screw into each of the three or four tapped holes and hand tighten using the 2.5 mm Allen key supplied.

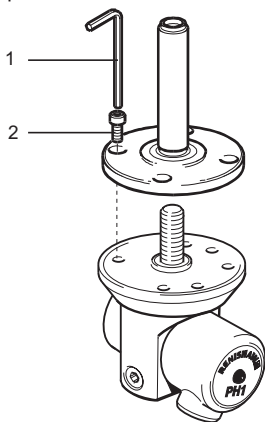

1. 2.5 mm AF Allen key
2. M3 x 6 mm Allen cap screw

Figure 22 – Attaching a Renishaw shank to a Renishaw manual probe head (PH1 shown)

The pin configuration and outputs are detailed below (see Table 4 and Figure 23).

The PH6 has an integral cable and connector. This will conform to the CMM manufacturer's specification. If the connector on the attached cable has a 5-pin DIN connection then, subject to external verification, the cable pin outputs will be as specified below.

The PH6M is fitted with an integral 15-pin micro 'D' socket. If required, this socket can be adapted by using a suitable cable to which a 5-pin DIN socket has been fitted.

Table 4 - DIN plug/socket functions		
Pin number	Function	Wire colour
1	LED cathode	Red
2	Screen	Screen
3	LED anode	Yellow
4	Probe circuit	Blue
5	Probe circuit	Green

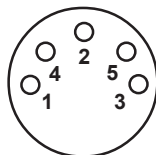

Figure 23 – Renishaw 5-pin DIN plug/socket (pin locations)

9.4 Connecting a manual probe head electrically to a CMM

All Renishaw manual probe heads (except the PH6 and PH6M) have an integral 5-pin DIN female connector. This connector is compatible with the Renishaw moulded 5-pin plug that is fitted to all Renishaw manual probe head cables.

10 Maintenance - Cleaning

Renishaw manual heads and touch-trigger probes are sealed, maintenance-free products. They may be wiped with a clean, dry, lint-free cloth. The units are not sealed against water.

11 Accessories

Please contact your Renishaw representative for further information on any of the accessories described in this section or for details of Renishaw's extensive range of innovative products for CMMs, machine tools, digitising, accuracy checking, calibration, scale systems and spectral analysis.

11.1 Styli

Renishaw manufacture an extensive range of precision styli and stylus accessories.

The Renishaw stylus range can be used with any probe covered in this guide and offers a variety of ball sizes in industrial ruby from 0.3 mm (0.012 in) to 8 mm (0.31 in) diameter. These are available with steel, tungsten carbide, ceramic and Renishaw Graphite Fibre (GF) stems to cover a wide range of applications.

Specialist application styli including discs, cylinders, pointers, stars and large ceramic balls - up to 30 mm (1.18 in) diameter - are available.

Renishaw also offer a custom design service if your requirements are not met by our standard range. Please contact your Renishaw representative for details.

For further information on the Renishaw stylus range, please refer to the Styli and Accessories Technical Specifications, Publication Number H-1000-3200.

12 Fault-finding guide

Use Table 5 below to identify the problem you are experiencing with your probe system and then refer to the relevant section in this guide.

Table 5 - Troubleshooting		
Observation	Section	Page
Poor measurement performance	12.1	61
Unwanted triggers during CMM movement	12.2	62
No probe signal	12.3	62
Probe fails to re-arm after trigger	12.4	63

If you experience problems which you are unable to identify or solve satisfactorily, please contact your Renishaw representative for further advice or contact the Technical Support Department at any Renishaw office for free assistance by telephone (see address list on rear cover).

12.1 Poor measurement performance

Possible cause	Checks/remedies
Probe or probe extension bar not installed correctly.	Remove probe and/or probe extension bar and re-fit using the S1 spanner as detailed in Section 10.
Stylus configuration too long or not rigid.	Use shorter/stiffer stylus configuration.
Poor stylus assembly.	Ensure that the number of stylus joints is kept to a minimum and all joints are clean and secure, as detailed in Section 5.1.
Contaminated/damaged stylus ball.	Inspect for damage, clean thoroughly with solvent.
Trigger force too high.	Decrease trigger force to the minimum necessary to ensure reliable triggering. See Section 5.2.
Too few points taken for probe qualification/measurement.	Take a larger number of points on the qualification/feature measurement.

12.2 Unwanted triggers during CMM movement

Table 7 - Unwanted triggers during CMM movement	
Possible cause	Checks/remedies
Trigger force set too low.	Increase trigger force to the minimum necessary to ensure reliable triggering. See Section 6.2.
Stylus configuration too heavy.	Reduce mass of stylus configuration. Reduce stylus length to minimum possible. Use a lightweight material for stylus configuration (GF or ceramic).

12.3 No probe signal

Table 8 - No probe signal	
Possible cause	Checks/remedies
Probe not installed correctly.	Remove probe and re-fit using the S1 spanner as detailed in Section 9.
Probe extension bar failure.	Check connections and integrity of probe extension bar. Contact your CMM supplier or Renishaw representative for further assistance.
Probe failure.	Contact your CMM supplier or Renishaw representative for further assistance.

12.4 Probe fails to re-arm after trigger

Table 9 - Probe fails to re-arm after trigger	
Possible cause	Checks/remedies
Trigger force set too low.	Increase trigger force to the minimum necessary to ensure reliable triggering. See Section 6.2.
Stylus configuration too heavy.	Reduce mass of stylus configuration. Reduce stylus length to minimum possible. Use a lightweight material for stylus configuration (GF or ceramic).
Probe reseal failure.	Retrigger probe. Many DCC CMMs will attempt to do this automatically (refer to your CMM supplier for details). If this problem persists, please return the probe to your Renishaw representative for service.

13 Technical product specifications

		TP1(S)	TP2 - 5 way	TP6/TP6A
Sense directions		$\pm X, \pm Y, +Z$	$\pm X, \pm Y, +Z$	$\pm X, \pm Y, +Z$
Uni-directional repeatability (max 2σ at stylus tip)		0.5 μm (0.00002 in)	0.35 μm (0.000014 in)	0.35 μm (0.000014 in)
Pre-travel variation over 360° (XY plane)		$\pm 2.0 \mu\text{m}$ (± 0.00008 in)	$\pm 0.8 \mu\text{m}$ (± 0.000032 in)	$\pm 0.6 \mu\text{m}$ (± 0.000024 in)
Trigger force range (adjustable)		10-50 g (0.35-1.76 oz)	7-15 g (0.25-0.53 oz)	11-30 g (0.39-1.06 oz)
Trigger force (set by Renishaw)		15 g (0.53 oz)	7-8 g (0.25-0.28 oz)	11-13 g (0.39-0.46 oz)
Stylus overtravel	XY axis	$\pm 19.5^\circ$ 8.5 mm (0.33 in)	$\pm 14^\circ$ 4.0 mm (0.16 in)	$\pm 22^\circ$ 5.5 mm (0.22 in)
	+Z axis	@ 10 g (0.35 oz) trigger force	@ 7 g (0.25 oz) trigger force	@ 11 g (0.39 oz) trigger force
	-Z axis	N/A	N/A	N/A
Test conditions	Trigger force	15 g (0.53 oz)	7-8 g (0.25-0.28 oz)	11-13 g (0.39-0.46 oz)
	Trigger speed	8 mm(0.32 in)/ sec	8 mm(0.32 in)/ sec	8 mm(0.32 in)/ sec
	Stylus used	PS1-1R	PS12R	PS1-12R
	Stylus length	31 mm (1.22 in)	10 mm (0.39 in)	21 mm (0.83 in)

Renishaw plc
New Mills, Wotton-under-Edge,
Gloucestershire, GL12 8JR
United Kingdom

T +44 (0)1453 524524
F +44 (0)1453 524901
E uk@renishaw.com
www.renishaw.com

RENISHAW 
apply innovation

**For worldwide contact details, please
visit our main website at
www.renishaw.com/contact**



* H - 1000 - 5021 - 06 - B *